

Fuel Tank

actually fuel tank system design and produce base frame type for compact and basic installation, for big size engines base frame has not enough capacity, For long term running capacity the fuel tanks design as an externally, and install separately

they supply fuel for a long time period and for continuous running, for hot climate and for cold climate keep the fuel more suitable form, more suitable degree

Larger size tank also prevent the engine to get the sink dust and dirt

Standart Features

- * inlet and outlets
- * outlet valve
- * drain
- * Filling cap
- * Mechanic gauge

Optional Features

- * Electronic Gauge
- * Low Fuel Alarm
- * Auto Fuel Filling Control
- * Fuel transfer pump
- * special dimension

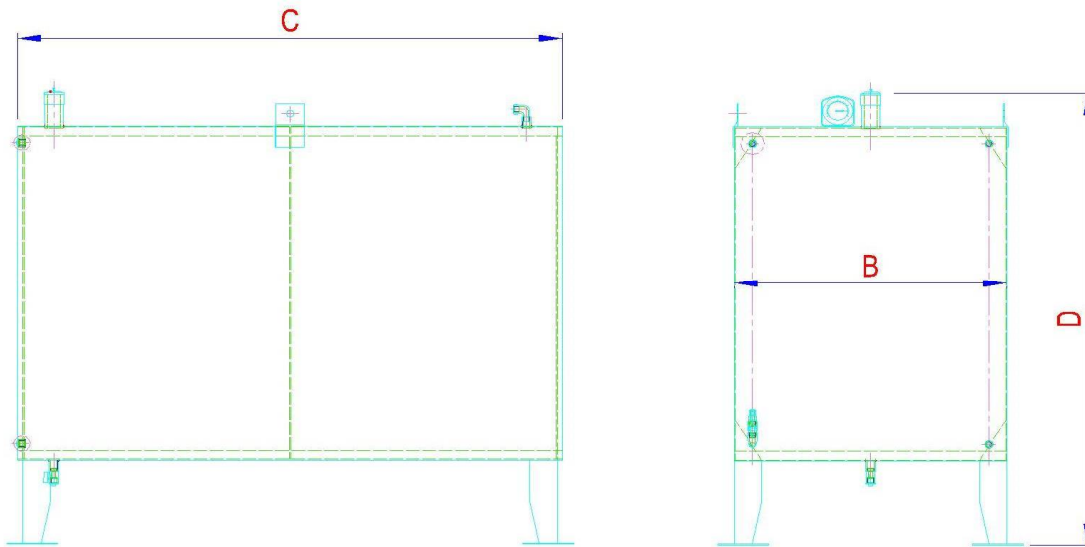

Silencer Ref.		A	B	C	D
	LİTER	mm	mm	mm	mm
FTE600	3MM	600	450	1500	1250
FTE1000	3MM	1000	750	1500	1250
FTE1500	3MM	1500	850	1500	1450
FTE2000	3MM	2000	1150	1500	1450
FTE2500	3MM	2500	1200	1500	1750
FTE3000	3MM	3000	1350	1500	1750
FTE4000	3MM	4000	1500	1750	1750
FTE5000	4MM	5000	1500	1500	2500